



# 优钻地质材料供应有限公司 PRE-MAT DRILLING SUPPLIES PTE LTD

Co Reg. No. 199900213-K GST Reg. No. 19-9900213-K  
No. 48 Toh Guan Road East #06-107 Enterprise Hub, Singapore 608586  
Tel: (65) 6861 5323 Fax: (65) 6861 0882 Mobile: (65) 9633 1617 / (65) 9665 2712  
Email: enquiry@premat.com.sg Website: <http://www.premat.com.sg>

## MAZIER RETRACTABLE CORE BARRELS

The MAZIER Retractable Core Barrel allows taking an undisturbed sample of soil by applying pressure. The rotation includes a frictionless design to have well coefficient close to zero.

The axial movement of the shoe from the bit allows an adaptation to the encountered formation which might be of different hardness and this avoids affecting the quality of sampling. The shoe being ahead of the bit stops water from eroding and disturbing the core.

### CHARACTERISTICS:

1. NIL Wall Coefficient
2. Entry Coefficient 3.5%
3. Grey/Clear Polyethylene Tube
4. Length of Sample: 1,000mm (1m)
5. Sealed Head Dampened with Oil
6. Moving Head in Hard Chromed Steel Placed in Bronze Bearing

Outer diameter	Core diameter	Thread of the head
*74 mm	52.00 mm	AW/BW Rod
86 mm	61.00 mm	NW/NWY Rod
*101 mm	74.00 mm	NW/NWY Rod
116 mm	86.00 mm	50 Craelius
131 mm	100.40 mm	50 Craelius
146 mm	108.50 mm	50 Craelius

\*Stock size available in Singapore

This core barrel can be equipped with a diamond bit and a conical core lifter to sample rock.

Sampled Rock:

- Soft Formation 0.1MPa to Hard Rock 5MPa

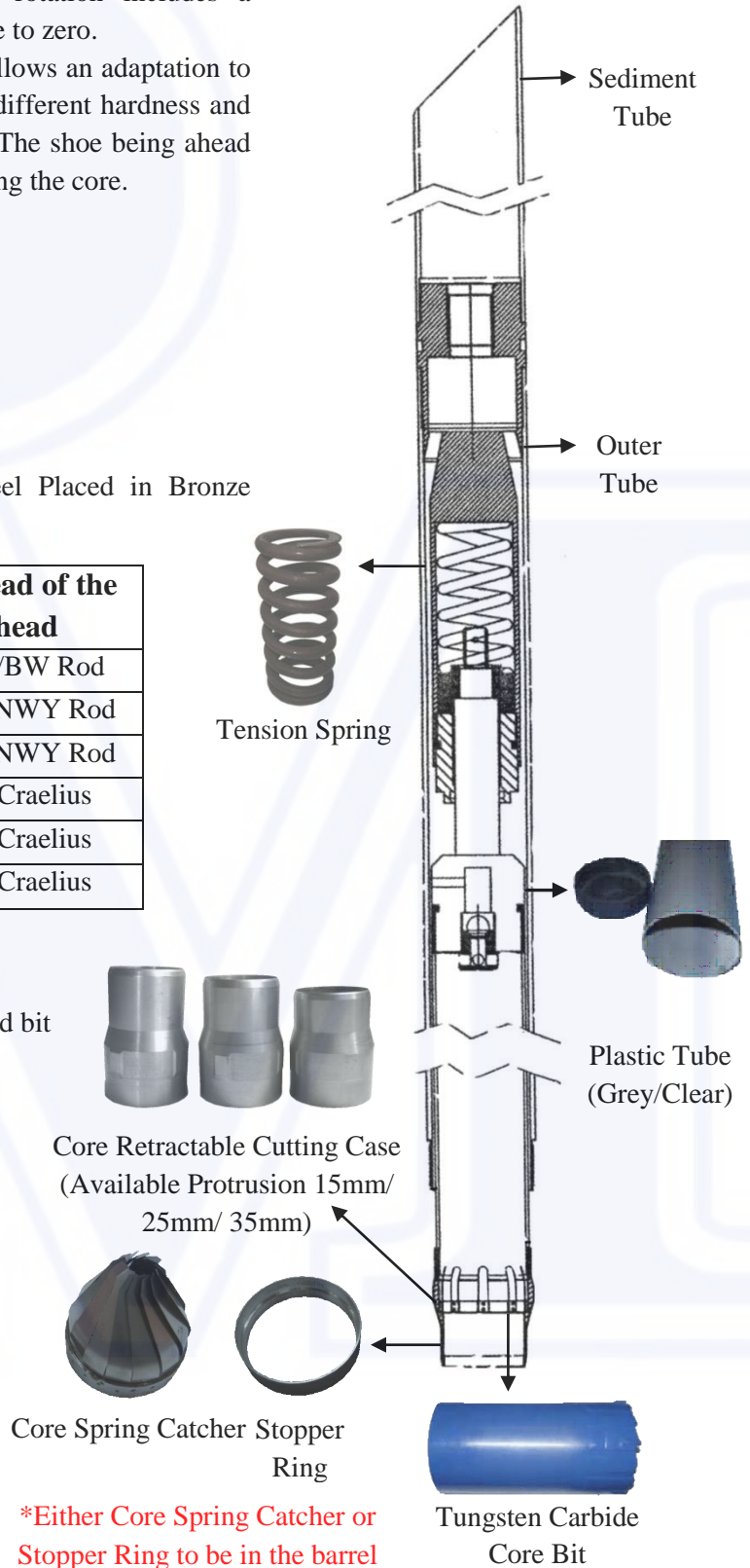

\*Either Core Spring Catcher or Stopper Ring to be in the barrel