



优钻地质材料供应有限公司
PRE-MAT DRILLING SUPPLIES PTE LTD

Co Reg. No. 199900213-K GST Reg. No. 19-9900213-K
No. 48 Toh Guan Road East #06-107 Enterprise Hub, Singapore 608586
Tel: (65) 6861 5323 Fax: (65) 6861 0882 Mobile: (65) 9633 1617 / (65) 9665 2712
Email: enquiry@premat.com.sg Website: <http://www.premat.com.sg>

TOHO D2-K92 P2 (FROM JAPAN)

Multi-Purpose Drilling Machine

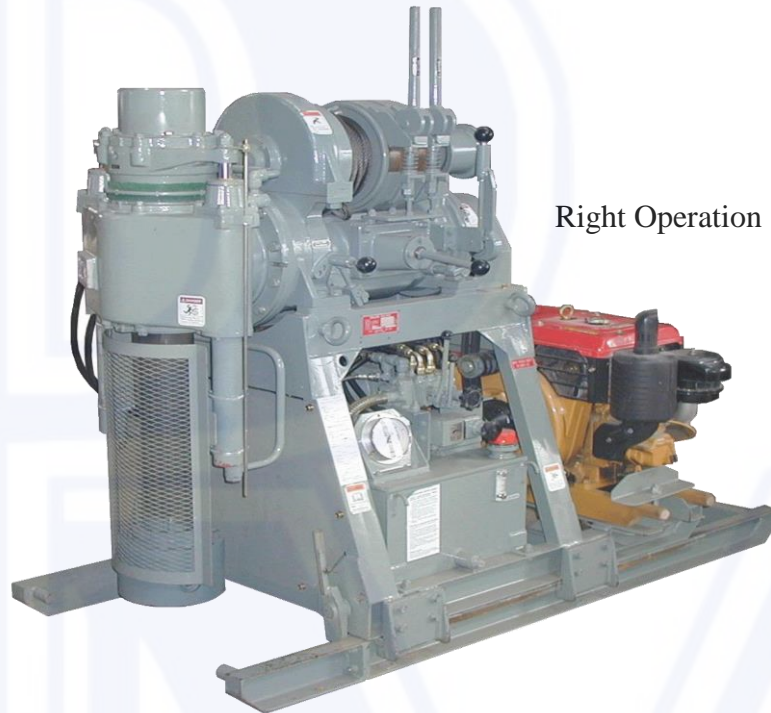

Right Operation

Right and left side operations are available

- *Soil Investigation*
- *Water Well*
- *Soil Foundation*

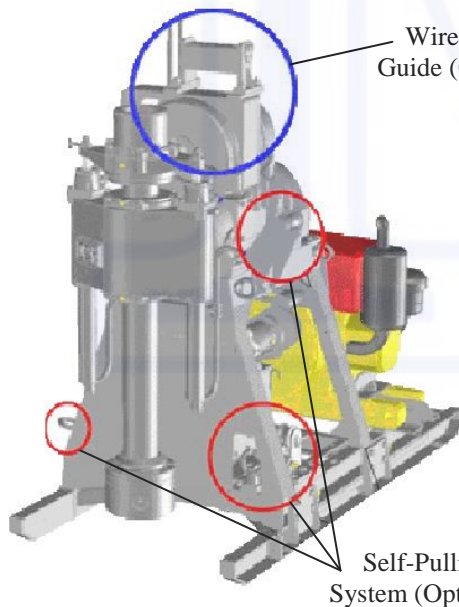

Wire Roller Guide (Optional)

Self-Pulling System (Optional)

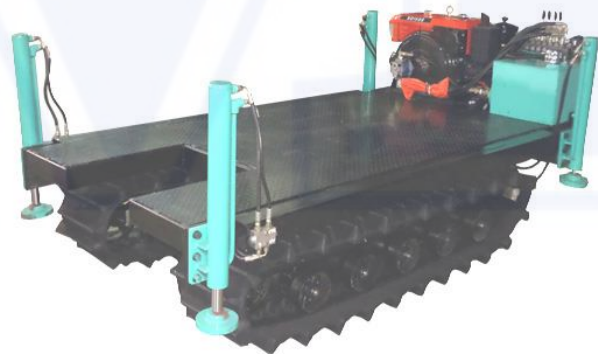

PM Crawler (Optional)

General View

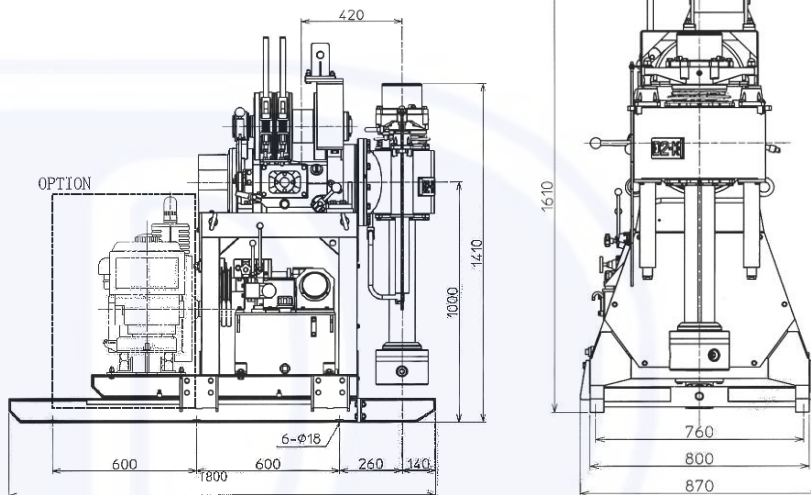

SPECIFICATIONS

DRILLING CAPACITY	*Depth 250 m/BW, 200 m/NW, 110 m/HW
SWIVEL HEAD	
Type	Twin cylinder, Oil-hydraulic feed system, Spindle type
Angle Range	360°
Operation Side	** (A) Right (B) Left
I.D of Spindle	92mm
Stroke of Spindle	500mm
Revolving Speed of Spindle	60 : 180 : 355 Reverse- 65 rpm
Max. Spindle Torque	1.18kN-m (120 kgf-m)
Max. Thrust Capacity	21.5kN (2200kgf) at Oil-hydraulic pressure 7.4MPa (75kg/cm ²)
Max. Balance Capacity	28.8kN (2900kgf) at Oil-hydraulic pressure 7.4MPa(75kg/cm ²)
Pod Chuck	Manual, Three(3) jaw type ***Oil-hydraulic four(4) jaw type
Main Clutch	Single plate, dry disc type
Transmission	Sliding gear, Three(3) speed and the reverse one(1) speed
HOIST DRUM	
Type	Planetary gear, hand brake type
Hoisting Capacity	14.7kN (1500kgf) at single pull line
Rope Speed	15 : 45 : 85 m/ min at single pull line
Drum Capacity	Ø10mm wire rope X 35m length
OIL -HYDRAULIC	
Type	Constant delivery, gear type pump
Delivery Capacity	20 l/min at 1600 rpm
Max. Pressure	7.4 MPa (75kg/cm ²)
FRAME RETRACTION	Oil-hydraulic slide, 400mm
POWER (recommended)	Electric Motor, 7.5kW, 3phase, 220V, 50 or 60Hz, or Diesel engine
	10PS(7.5kW) at 1800 rpm (rated cont. output)
NET WEIGHT	700kgf (without power) 800kgf (with oil-hydraulic chuck without power)
DIMENSION (LXWXH)	1800 x 870 x 1620 mm 1800 x 870 x 1655 mm (with oil-hydraulic chuck)
Remarks	*Drilling capacity calculated based on rod weight only.
	** (A) is standard, (B) is option. Please specify selection when ordering
	*** Option, please specify selection when ordering.

TOHO D2K92 P2

(WITH PULLEY SYSTEM & WIRE ROLLER GUIDE ASSEMBLY)

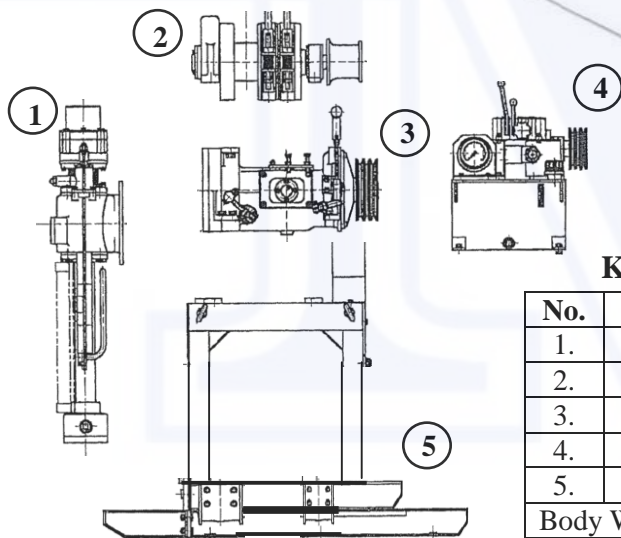
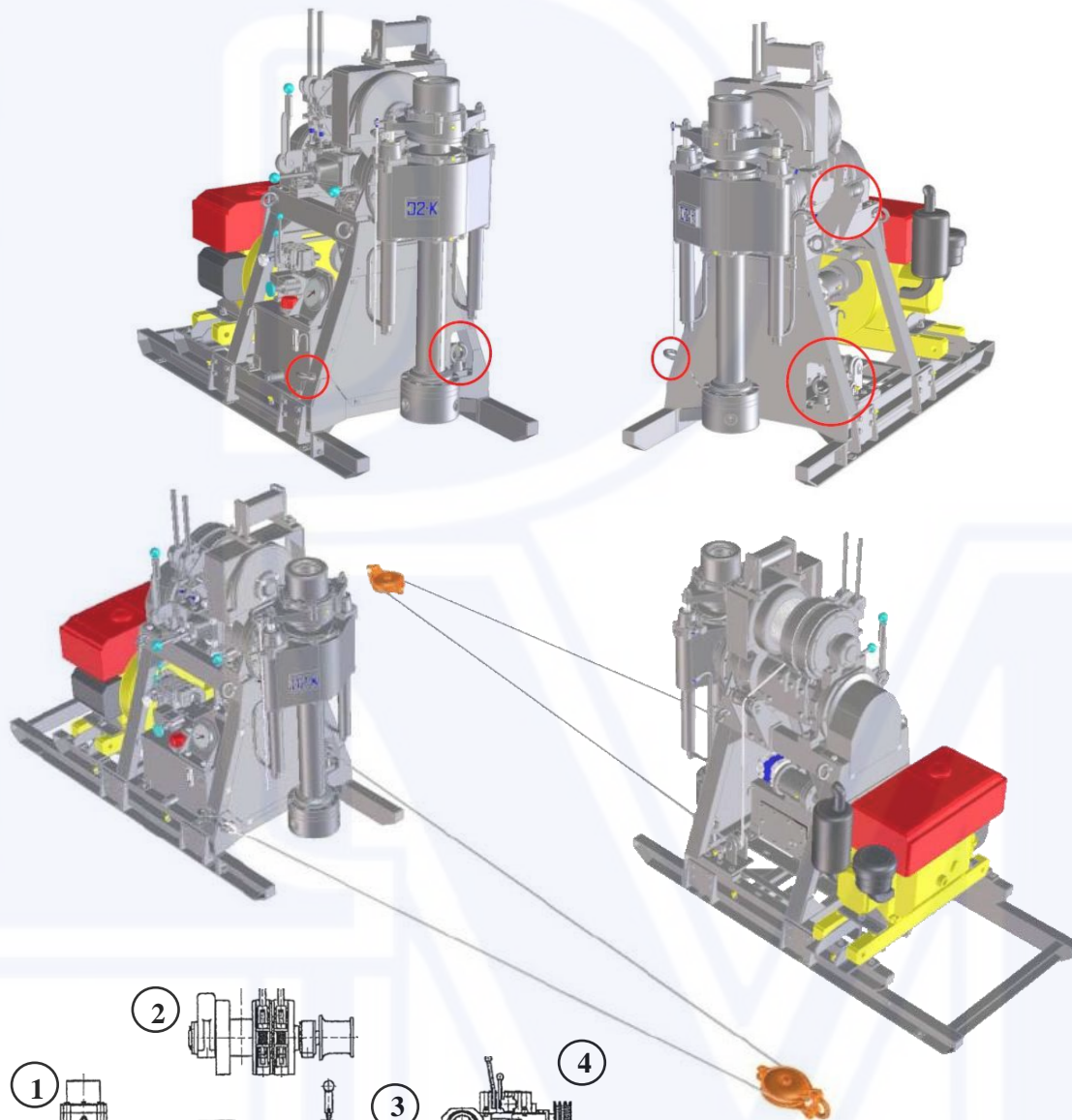

Knock-Down & Complete Weight Table

No.	Section	Weight (kg)
1.	Feed Complete	165
2.	Drum Complete	100
3.	Gear Case Complete	140
4.	Oil Tank Complete	115
5.	Frame & Slide Base Complete	180
Body Weight (kg), without prime mover		700