

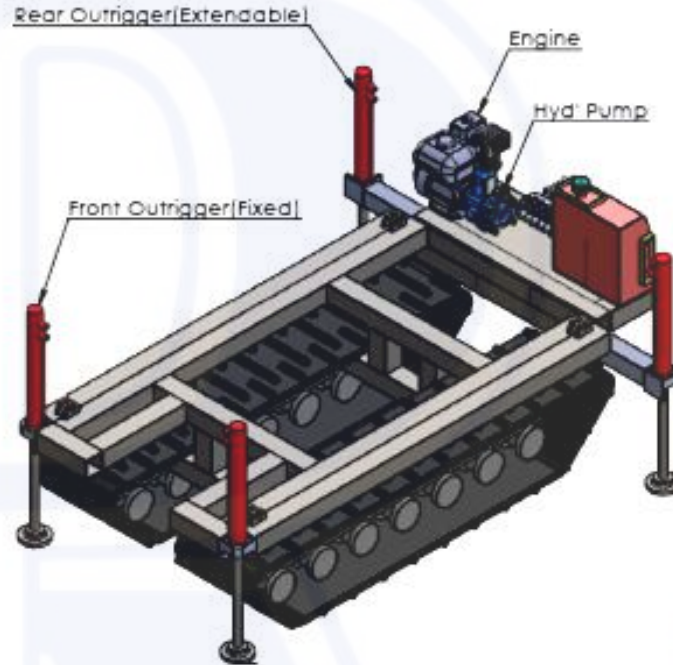

# 优钻地质材料供应有限公司 PRE-MAT DRILLING SUPPLIES PTE LTD

Co Reg. No. 199900213-K GST Reg. No. 19-9900213-K  
No. 48 Toh Guan Road East #06-107 Enterprise Hub, Singapore 608586  
Tel: (65) 6861 5323 Fax: (65) 6861 0882 Mobile: (65) 9633 1617 / (65) 9665 2712  
Email: enquiry@premat.com.sg Website: <http://www.premat.com.sg>

## PM CRAWLER



Model	PM-3T-RT-D CRAWLER
Capacity	3- Tons
Power Unit	9~10 HP Diesel Engine (Electric Start)
Track Type	2x Rubber Type 450mm (W) x 1500mm (L)
Front Outrigger	Fixed, Hydraulic Driven with Balancing Valve
Back Outrigger	Extendable, Hydraulic Driven
Flat Bed Size	2500mm (L) x 1450mm (W)
Overall Size	3050mm (L) x 1550mm (W) x 1100mm (H)
Flat Bed Height	600mm (from ground)
Flat Bed Opening	500mm x 600mm
Weight	1550kgs

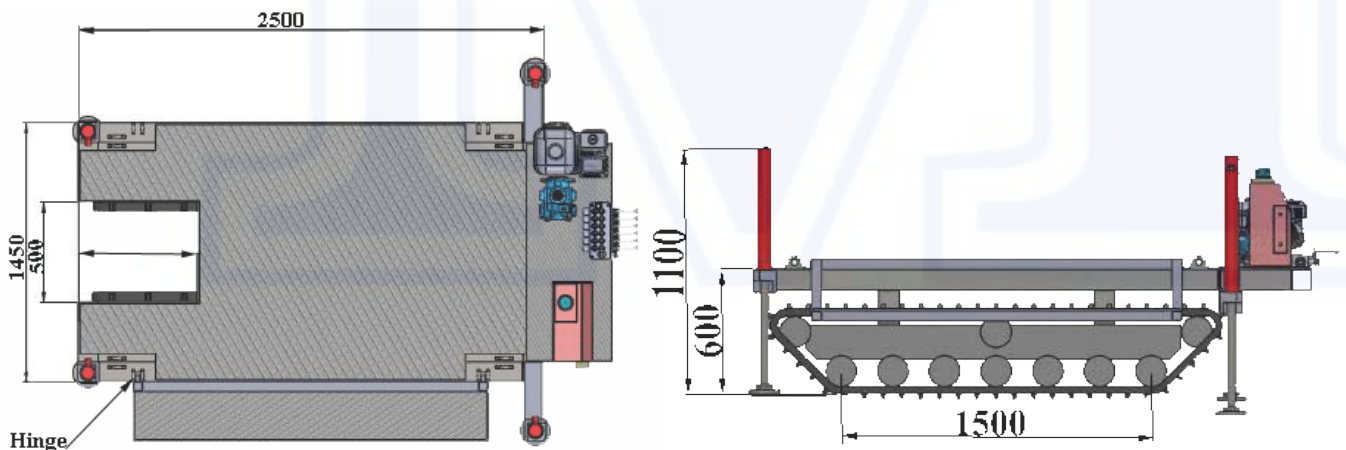

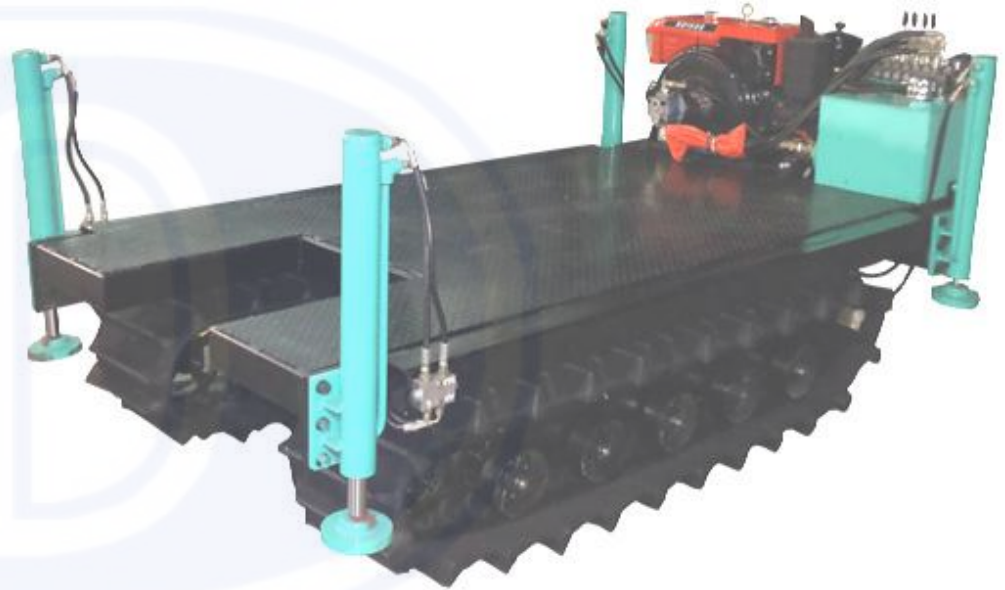

## PM CRAWLER



**PM-3T-RT-D Crawler**



**PM-2T-RT-D Crawler**